



All tests reported herein have been performed in accordance with the laboratory's scope of accreditation

## Safety Clearance Summary.

### Client Details:

Company Name: Glen Dimplex New Zealand Ltd.  
 Company Address: 38 Harris Rd, East Tamaki, Auckland.  
 Phone: 09-274 8265.  
 Test Report number: #0516.  
 Appliance: Nectre N15 Rural.  
 Tested Standard: AS/NZS 2918:2001 – Appendix B.  
 Test Fuel: Softwood (Pinus Radiata).  
 Flue System: 150 mm painted (tested to AS/NZS 2918:2001 – Appendix F) with 900 mm Masport stainless double flue shield.  
 Floor Protector: Minimum 450 mm in front of fuel loading opening and insulated with minimum 12 mm non-combustible material.  
 Ceiling Plate: 345 mm x 345 mm (180 mm hole, spaces 12.5 mm from ceiling surface)

### Test Results for High/Flash fire without side shields:

Parallel Position Clearance Distance (Without Side Shields)	Position	Clearance (mm)
	(A) Rear	200
	(B) Side	700
	(C) Floor protector (front)	450
	(D) Floor protector (side)	380

Corner Position Clearance Distance (Without Side Shields)	Position	Clearance (mm)
	(F) Side	480
	(G) Side	480
	(H) Floor protector (front)	450
	(I) Floor protector (side)	380

**Test Results for High/Flash fire with side shields:**

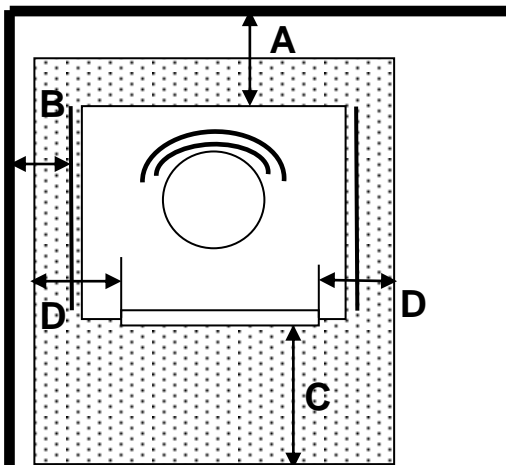
Parallel Position Clearance Distance (With Side Shields)	Position	Clearance (mm)
	(A) Rear	150
	(B) Side	422
	(C) Floor protector (front)	450
	(D) Floor protector (side)	330

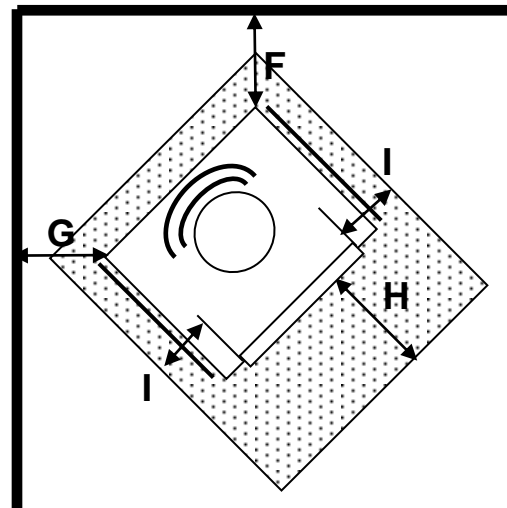
Corner Position Clearance Distance (With Side Shields)	Position	Clearance (mm)
	(F) Side	280
	(G) Side	280
	(H) Floor protector (front)	450
	(I) Floor protector (side)	330

  
 -----  
 Checked by  
 Mr. P. Sparrow  
 Authorized Signatory

  
 -----  
 Tested by  
 Mr. P. Chen  
 Compliance Engineer

Issue Date: 06/11/2018